

GUIDE MARKER
TYPE F (1)

CLEARANCE MARKER
TYPE L(2) AND L(3)

ALTERNATE* PLASTIC MARKER
"AUTOPOST" OR EQUAL AS
APPROVED BY ENGINEER

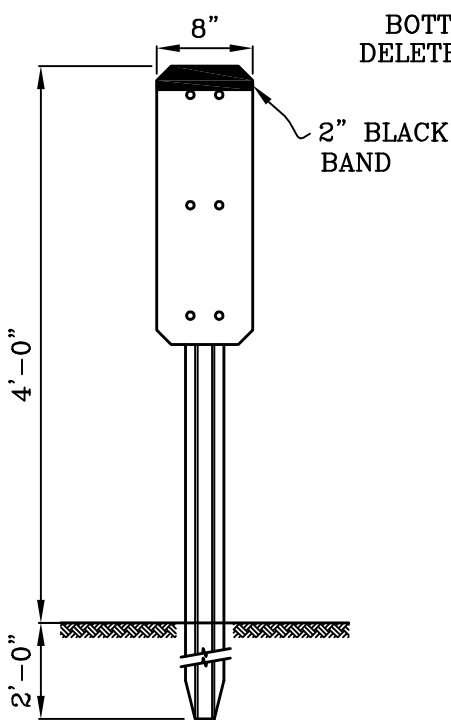
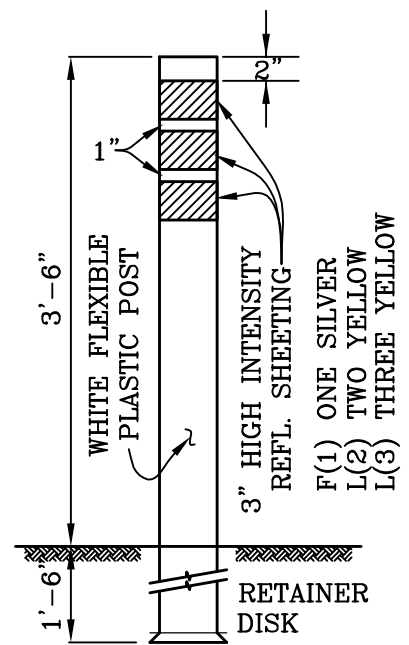

CULVERT MARKER

BOTTOM REFLECTOR
DELETED ON TYPE L(2)

*ALTERNATE PLASTIC MARKERS
SHALL BE USED WHERE SPECIFIED
OR WHERE PROBABILITY OF
VEHICLE IMPACT IS HIGH.

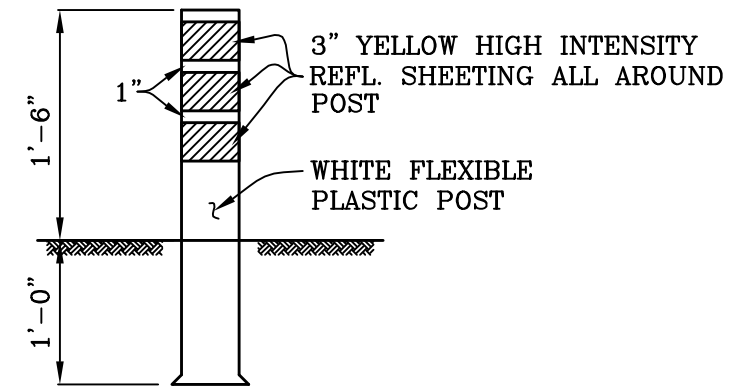

ISLAND NOSE MARKER

"AUTOPOST" OR EQUAL AS
APPROVED BY ENGINEER

SEE SHEETS 2 AND 3 FOR PLACEMENT AND NOTES

CITY OF MISSION VIEJO



MARKERS

STANDARD
PLAN NO.

503

Robert Anderson

9-23-03

APPROVED

RCE 30190

DATE

SHT 1 OF 3

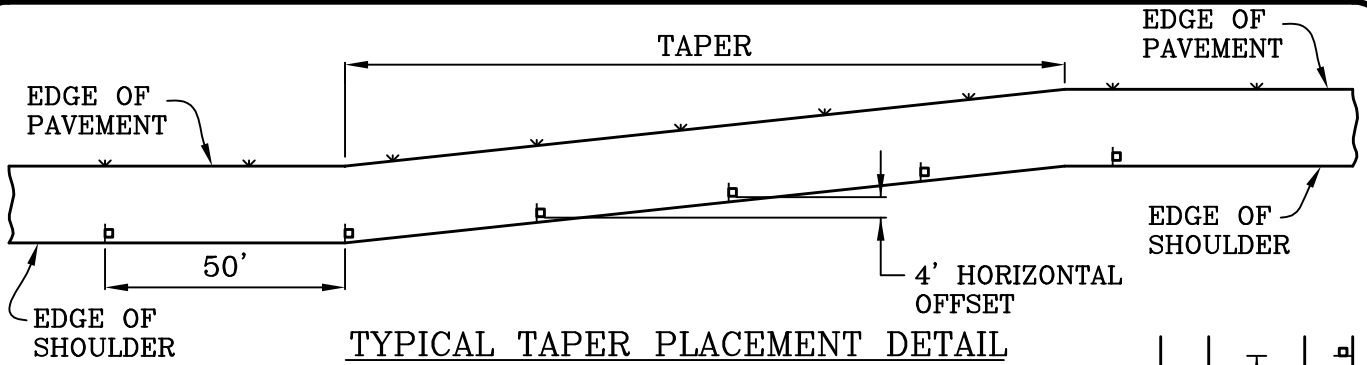

TYPICAL TAPER PLACEMENT DETAIL

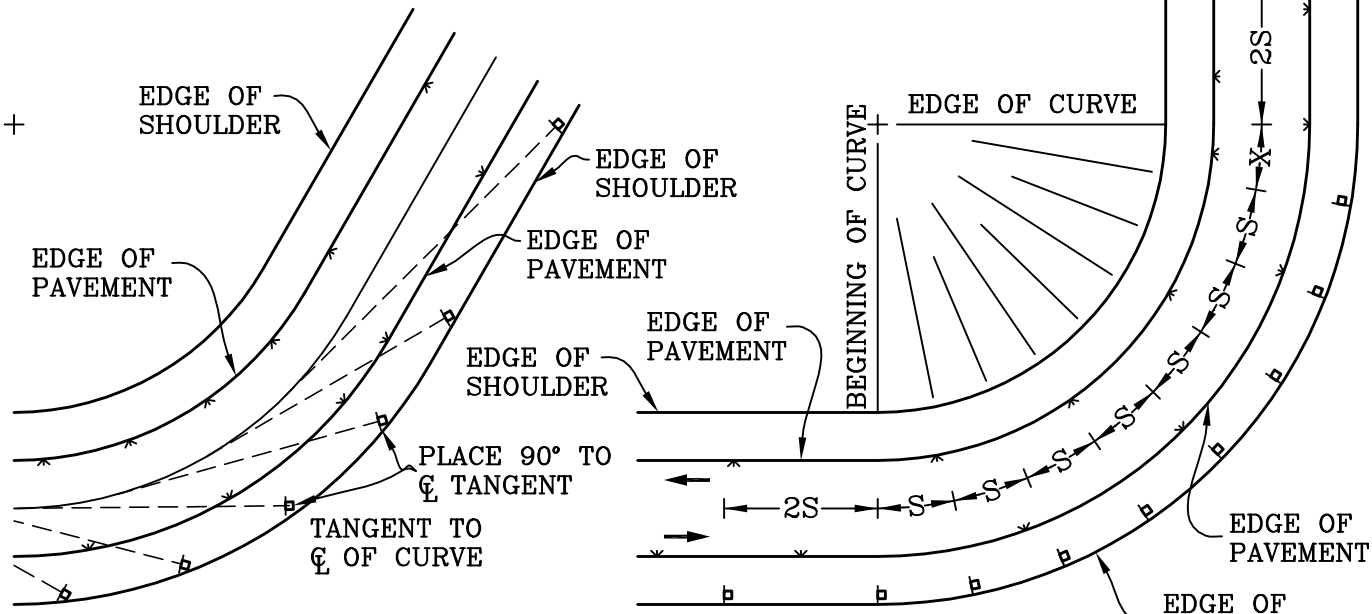

CURVE PLACEMENT DETAIL

SPACING DETAIL

R(FT.)	S(FT.)	R(FT.)	S(FT.)
50	20	700	75
75	20	800	80
100	25	900	85
150	30	1000	90
200	35	1200	100
300	50	1400	110
400	55	1600	115
500	65	1800	125
600	70	2000	130

- NOTES:
1. MAX. SPACING BETWEEN GUIDE MARKERS = 300'. MIN. SPACING = 20'.
 2. GUIDE MARKER SPACING ON CURVES LESS THAN 2000' RADIUS SHALL CONFORM TO THAT SPACING INDICATED IN TABLE 1.
 3. PRORATE DISTANCE X AMONG ALL SPACINGS WITHIN CURVE SO LAST GUIDE MARKER FALLS AT END OF CURVE.

LEGEND:
 S = GUIDE MARKER SPACING IN FEET.
 $S = 3\sqrt{R-50}$
 R = CENTERLINE CURVE RADIUS IN FEET.
 p = GUIDE MARKER
 X = DISTANCE REMAINING WITHIN CURVE FROM LAST CALCULATED GUIDE MARKER TO END OF CURVE.

CITY OF MISSION VIEJO



MARKERS

Robert Anderson 9-23-03
 APPROVED RCE 30190 DATE

STANDARD PLAN NO.

503

SHT 2 OF 3

NOTES:

USE OF GUIDE MARKERS AND CLEARANCE MARKERS ON CITY ROADS SHALL CONFORM TO THE FOLLOWING.

1. GUIDE MARKER F(1)
 - a. ON ROADWAY CURVES OF LESS THAN 2000 FT. RADIUS, PLACE AS PER CHART ON SHEET 2.
 - b. ON SHOULDERS ON TANGENTS WHERE THE FILL HEIGHT EXCEEDS 6 FT., PLACE AT 300 FT. INTERVALS.
 - c. ON PAVEMENT OR ROADWAY TAPERS, PLACE FOR 4 FT. HORIZONTAL OFFSET.
2. CLEARANCE MARKERS L(2)
 - a. USED ON SHARP OR SUBSTANDARD CURVES.
 - b. ON THE APPROACH SIDE OF RURAL INTERSECTIONS.
 - c. ON DETOURS.
 - d. FOR OTHER SPECIAL DELINEATION.
3. CLEARANCE MARKER L(3)
 - a. ALONG PEDESTRIAN PATHS OR BIKE WAYS FOR SEPARATION FROM VEHICULAR TRAFFIC.
 - b. FOR OBSTRUCTION LESS THAN 8 FT. FROM THE EDGE OF PAVEMENT, INCLUDING BRIDGE ABUTMENTS.
 - c. FOR WIDENED SECTIONS, PER STD. PLAN 501.
4. ISLAND NOSE MARKER
 - a. IN THE FAR NOSE OF MEDIAN ISLANDS AT OPENINGS AND INTERSECTIONS.
 - b. FACING APPROACHING TRAFFIC AT THE POINTS OF ISLANDS FORMING RIGHT TURN LANES.
 - c. WHERE TRAFFIC DIVIDES AND MAY PROPERLY GO TO EITHER SIDE OF ISLAND.
5. CULVERT MARKER
 - a. LOCATE AT EDGE OF SHOULDER OPPOSITE THE END OF CULVERT.

CITY OF MISSION VIEJO



MARKERS

STANDARD
PLAN NO.

503

Roy Anderson 9-23-03

APPROVED RCE 30190 DATE

SHT 3 OF 3